

LM2747 Evaluation Board

National Semiconductor
Application Note 1449
Maurice Eaglin
April 2006



Introduction

This application notes describes the LM2747 printed circuit board (PCB) design and provides an example typical application circuit. The demo board allows component design flexibility in order to demonstrate the versatility of the LM2747 IC.

The demo board contains a voltage-mode, high-speed synchronous buck regulator controller. Though the control sections of the IC are rated for 3 to 6V (V_{CC}), the driver sections are designed to accept input supply rails (V_{IN}) as high as 14V.

The demo board design regulates to an output voltage of 1.2V at 3.5A with a switching frequency of 1MHz from a 1 MHz clock source that has an amplitude from 0V to V_{CC} . Note, the demo board is optimized for a 1MHz, 14V input voltage compensation design with $V_{CC} = 3.3V$. If a slower switching frequency and input voltage is desired, please consult the device data sheet for control loop compensation procedures. For additional design modifications refer to the Design Consideration section of the LM2747/8 data sheet.

The demo board accommodates the use of banana clips to clip onto pads on the board, if preferred, the pads inner diameters are 100mils, for which a solder terminal can be placed (Newark 40F6004). The PCB is designed on two layers with 1oz. copper on a 62mil FR4 laminate.

Additional Footprints

An additional footprint D1 is available for a Schottky diode to be placed in parallel with the low side MOSFET. This component can improve efficiency, due to the lower forward drop than the low side MOSFET body diode conducting during the anti-shoot through period. Select a Schottky diode that maintains a forward drop around 0.4 to 0.6V at the maximum load current (consult the I-V curve). In addition select the reverse breakdown voltage to have sufficient margin above the maximum input voltage.

Footprint C13 is available for a multilayer ceramic capacitor (MLCC) connected flush to the source of the low side MOSFET and drain of the high side MOSFET, in order to provide low supply impedance. For example, component C13 is used in combination with aluminum electrolytic input filter capacitors, placed in designators C12 and C14. If MLCCs are used in designators C12 and C14 component C13 is not necessary.

Typical Application Circuit

The typical application circuit in figure 1 provides the component designators used on the demo board.

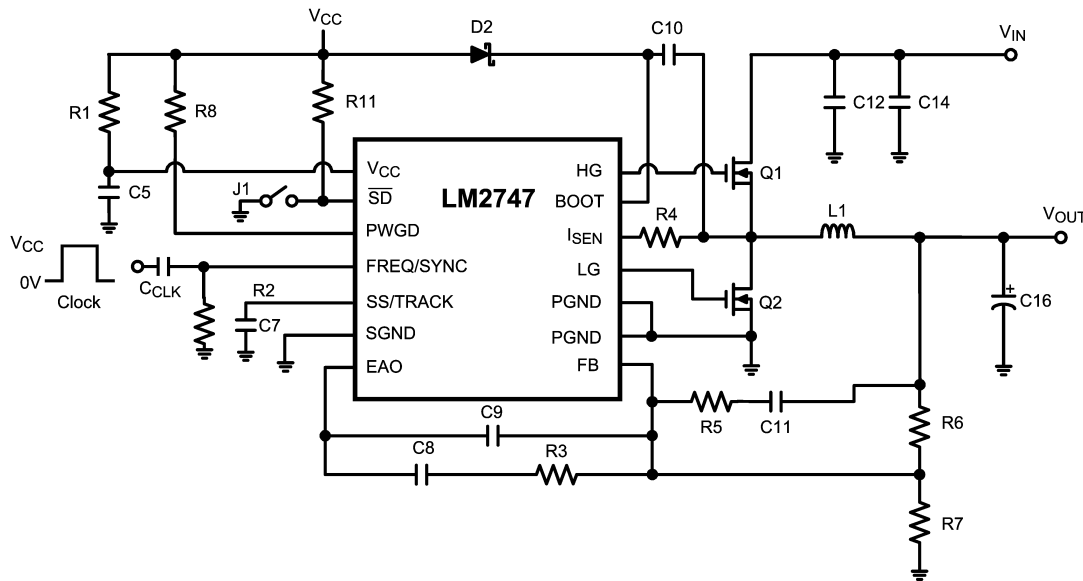

20184101

FIGURE 1. Typical Application

Performance Characteristics (Output Ripple Voltage and Switch Node Voltage)

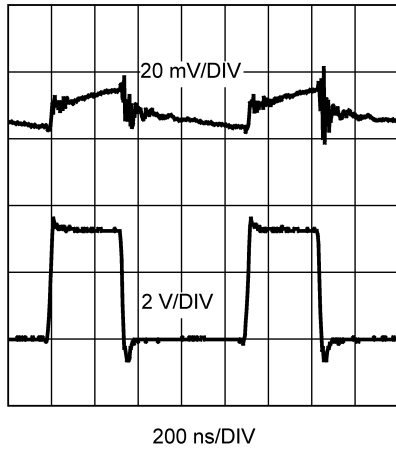

20184105

FIGURE 2. $V_{IN} = V_{CC} = 3.3V$,
 $V_{OUT} = 1.2V$, $I_{LOAD} = 0A$, $f_{SW} = 1MHz$
20 MHz Bandwidth Limit

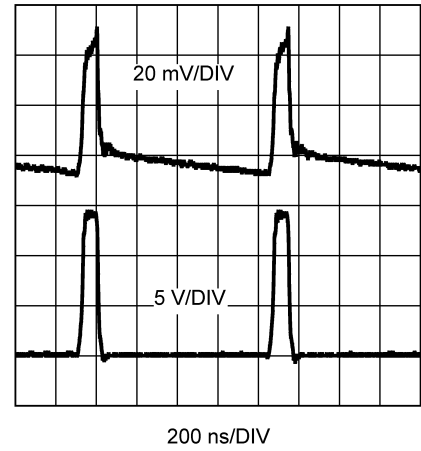

20184107

FIGURE 4. $V_{IN} = 14V$, $V_{CC} = 5V$,
 $V_{OUT} = 1.2V$, $I_{LOAD} = 0A$, $f_{SW} = 1MHz$.
20 MHz Bandwidth Limit

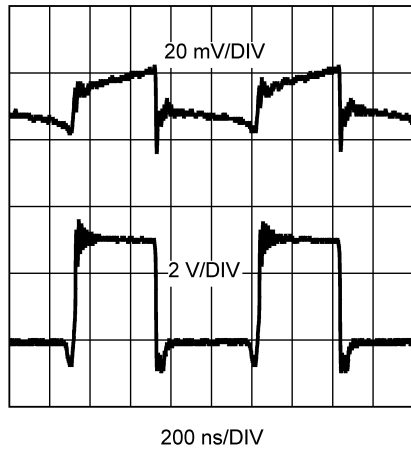

20184106

FIGURE 3. $V_{IN} = V_{CC} = 3.3V$,
 $V_{OUT} = 1.2V$,
 $I_{LOAD} = 3.5A$, $f_{SW} = 1MHz$.
20 MHz Bandwidth Limit

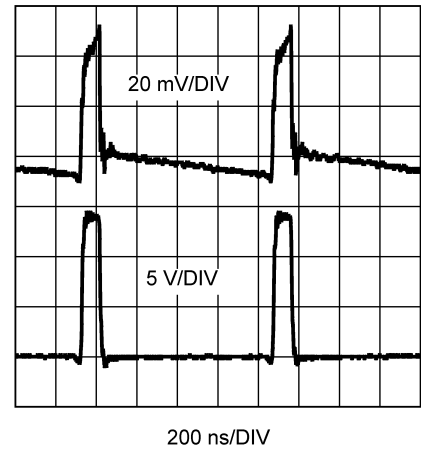

20184108

FIGURE 5. $V_{IN} = 14V$, $V_{CC} = 5V$,
 $V_{OUT} = 1.2V$, $I_{LOAD} = 3.5A$, $f_{SW} = 1MHz$.
20 MHz Bandwidth Limit

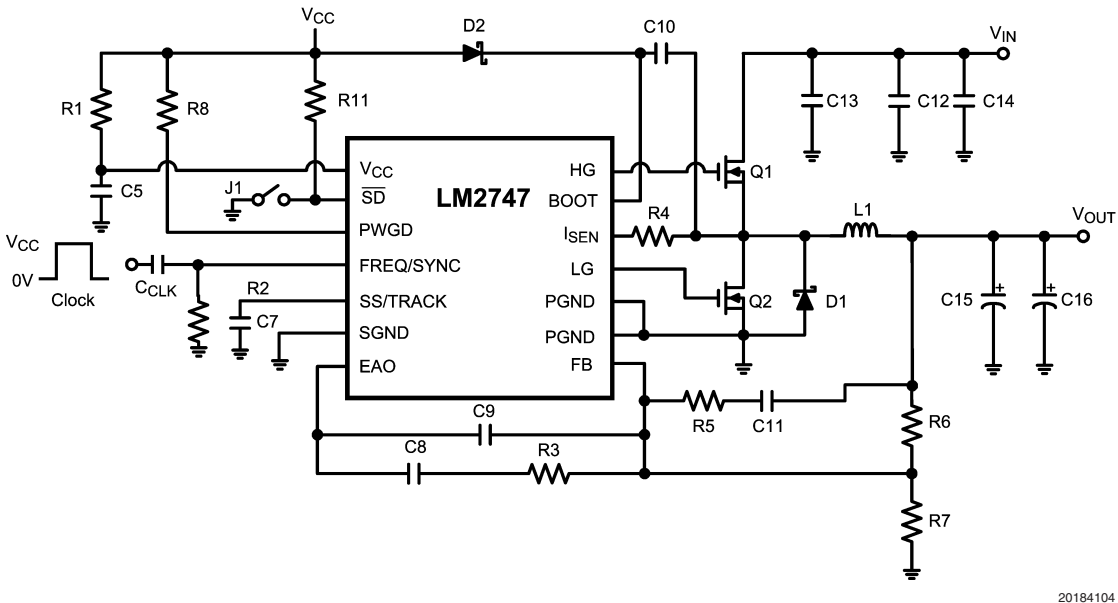

20184104

FIGURE 6. Complete Demo Board Schematic

Bill of Materials

Designator	Function	Part Description	Part Number
U1	Controller	LM2747 TSSOP14	National Semiconductor
C5	VCC Decoupling	Cer Cap 1 μ F 25V 10% 0805	Murata GRM216R61E105KA12B
C7	Soft Start Cap	Cer Cap 12 nF 25V 10% 0805	Vishay VJ0805Y123KXX
C8	Comp Cap	Cer Cap 1.5 nF 25V 10% 0805	Vishay VJ0805Y152KXX
C9	Comp Cap	Cer Cap 18 pF 25V 10% 0805	Vishay VJ0805A180KAA
C10	Cboot	Cer Cap 0.1 μ F 25V 10% 0805	Vishay VJ0805Y104KXX
C11	Comp Cap	Cer Cap 1.8nF 25V 10% 0805	Vishay VJ0805Y182KXX
C12	Input Filter Cap	Cer Cap 10 μ F 25V 10% 1210	AVX 12103D106MAT
C14	Input Filter Cap	Cer Cap 10 μ F 25V 10% 1210	AVX 12103D106MAT
C15	Output Filter Cap	470 μ F, 6.3V, 10m Ω ESR POScap	Sanyo 6TPD470
R1	Filter Resistor	Res 10 Ω .25W 0805	Vishay CRCW08051000F
R2	Frequency Adjust Res	Res 18.7k Ω .25W 0805	Vishay CRCW08052187F
R3	Comp Res	Res 17.4k Ω .25W 0805	Vishay CRCW08051742F
R4	Current Limit Res	Res 3.16k Ω .25W 0805	Vishay CRCW08053161F
R5	Comp Res	Res 2.94k Ω .25W 0805	Vishay CRCW08052941F
R6	Res Divider, upper	Res 10.0k Ω .25W 0805	Vishay CRCW08051002F
R7	Res Divider, lower	Res 10.0k Ω .25W 0805	Vishay CRCW08051002F
R8	PWGD Pull-Up	Res 100k Ω .25W 0805	Vishay CRCW08051003F
R11	Shut Down Pull-Up	Res 100k Ω .25W 0805	Vishay CRCW080561003F
D2	Bootstrap Diode	Schottky Diode, SOD-123	MBR0530LTI
L1	Output Filter Inductor	Inductor 1 μ H, 5.3Arms, 10.2m Ω	Cooper DR73-1R0
Q1-Q2	Top and Bottom FETs	Dual N-MOSFET, $V_{DS} = 20V$, 24m Ω @ 2.5V	Vishay 9926BDY
C _{CLK}	Sync AC Coupling Cap	Cer Cap 56 pF 25V 10% 0805	Vishay VJ0805A560KXAA

PCB Layout Diagrams

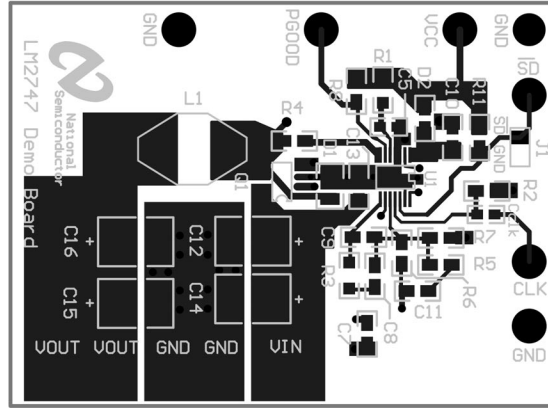

20184102

FIGURE 7. Top Layer and Top Overlay

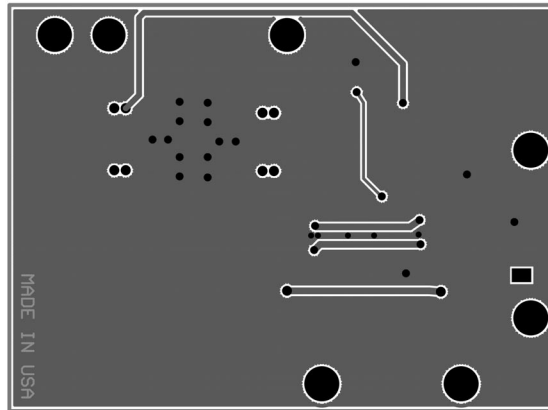

20184103

FIGURE 8. Bottom Layer

Notes

National does not assume any responsibility for use of any circuitry described, no circuit patent licenses are implied and National reserves the right at any time without notice to change said circuitry and specifications.

For the most current product information visit us at www.national.com.

LIFE SUPPORT POLICY

NATIONAL'S PRODUCTS ARE NOT AUTHORIZED FOR USE AS CRITICAL COMPONENTS IN LIFE SUPPORT DEVICES OR SYSTEMS WITHOUT THE EXPRESS WRITTEN APPROVAL OF THE PRESIDENT AND GENERAL COUNSEL OF NATIONAL SEMICONDUCTOR CORPORATION. As used herein:

1. Life support devices or systems are devices or systems which, (a) are intended for surgical implant into the body, or (b) support or sustain life, and whose failure to perform when properly used in accordance with instructions for use provided in the labeling, can be reasonably expected to result in a significant injury to the user.
2. A critical component is any component of a life support device or system whose failure to perform can be reasonably expected to cause the failure of the life support device or system, or to affect its safety or effectiveness.

BANNED SUBSTANCE COMPLIANCE

National Semiconductor manufactures products and uses packing materials that meet the provisions of the Customer Products Stewardship Specification (CSP-9-111C2) and the Banned Substances and Materials of Interest Specification (CSP-9-111S2) and contain no "Banned Substances" as defined in CSP-9-111S2.

Leadfree products are RoHS compliant.



National Semiconductor
Americas Customer
Support Center
Email: new.feedback@nsc.com
Tel: 1-800-272-9959

www.national.com

National Semiconductor
Europe Customer Support Center
Fax: +49 (0) 180-530 85 86
Email: europe.support@nsc.com
Deutsch Tel: +49 (0) 69 9508 6208
English Tel: +44 (0) 870 24 0 2171
Français Tel: +33 (0) 1 41 91 8790

National Semiconductor
Asia Pacific Customer
Support Center
Email: ap.support@nsc.com

National Semiconductor
Japan Customer Support Center
Fax: 81-3-5639-7507
Email: jpn.feedback@nsc.com
Tel: 81-3-5639-7560